



**PARTITION SYSTEMS INTERNATIONAL
OF SOUTH CAROLINA**

"Promoting a Greener Environment"

A DIVISION OF CSiSC®

HD-58134

Toilet Partition Installation Manual

PHONE: 803-252-3020

FAX: 803-256-7769

ATTENTION

DO NOT MIX
FASTENER PACKS

**EACH FASTENER PACK HAS THE NECESSARY
BOLTS, BARRELS AND SCREWS TO INSTALL
THE RESPECTIVE PANEL, PILASTER OR DOOR.**











**TORX HEAD BITS ARE PACKED IN THE EXTRA
FASTENER PACKS.**

TABLE OF CONTENTS

<u>STEP</u>		<u>PAGE</u>
1	TOOLS REQUIRED	4
2	GETTING STARTED	5
3	MARK THE PARTITION LAYOUT	6
4	INSTALL THE PANELS	8
5	INSTALL THE WALL PILASTER	
	5A USING 'Z' BAR ANCHORING SYSTEM.....	10
	5B USING STANDARD LEVELING DEVICE	12
6	INSTALL THE PILASTERS.....	14
7	INSTALL THE HEADRAIL	17
8	ATTACH THE DOORS	18
9	ATTACH THE DOOR HARDWARE	20
10	ADJUSTABLE ALUMINUM PILASTERS .	21
11	BOLT AND BARREL SIZES.....	23

1 TOOLS REQUIRED

- TAPE MEASURE
- 4 FOOT LEVEL
- RATCHET TYPE BIT DRIVER (torx head bits supplied)
- FLAT HEAD SCREWDRIVER
- PHILLIPS HEAD SCREWDRIVER
- 1 WAY SCREWDRIVER
- TWO 9/16" OPEN END WRENCHES
- HAMMER
- TWO 12" BLOCKS
- DRILL
- ROTARY HAMMER DRILL
- HACKSAW
- 5/16" CARBIDE TIPPED HAMMER DRILL BIT
- 5/8" CARBIDE TIPPED HAMMER DRILL BIT
- 1/4" HIGH SPEED STEEL DRILL BITS
- CHALK BOX

FA-900	1/2" BOLT	
FA-901	3/4" BOLT	
FA-902	15/16" BOLT	
FA-903	1-1/16" BOLT	
FA-904	1-3/16" BOLT	
FA-609	5/8" BOLT	
FA-652	1/2" BARREL	
FA-950	1/2" BARREL	
FA-951	5/8" BARREL	
FA-808	2" SCREW	
FA-400	PLASTIC ANCHOR	
FIGURE 11 FASTENER DETAIL		

2 GETTING STARTED

- 2.1 Find the packing list in the box marked “Packing List”
- 2.2 Check delivered materials and make sure no parts are damaged or missing.
- 2.3 Check dimensions in each bathroom against the shop drawings marked “For Field Use”. Make notes of differences.
- 2.4 Clear bathrooms to provide workroom.

Thank you for choosing partitions from Partition Systems International of South Carolina. We appreciate your business. At Partition Systems, we strive to provide the industry’s best partitions with comprehensive installation guides.

If you need assistance, have questions or comments; contact our customer service department at:

Customer Service
Partition Systems International of South Carolina

9031 Farrow Rd, Columbia, SC 29203

(803) 252-3020, Fax: (803) 252-6030

customer.service@psisc.com

3 MARK THE PARTITION LAYOUT

- 3.1 Establish and mark the center of the panels across the back wall according to shop drawings. For end-panels and alcove-panels mark the outer edge. (See fig.3.1)
- 3.2 Establish and mark the panel-brackets on the back wall 18" and 64" from the finished floor.
- 3.3 Establish and mark the wall-pilaster location on the side wall according to shop drawings. (See fig.3.1)
- 3.4 Establish and mark the pilaster-brackets on the side wall 18" and 64" from the finished floor.
- 3.5 Establish and mark the outer edges of each pilaster from the back and side walls according to shop drawings. (See fig.3.1)
- 3.6 Mark and drill holes for the floor fasteners.
 - 3.6.1 For "Z" bar anchoring system, mark 5/8" in from the end of the pilaster(s), centered from front to back. Drill a 2" deep hole in the floor with a 5/8" bit.
 - 3.6.2 For standard leveling device, place the shoe on the floor centered between the outer edges of the pilaster. Using the shoe as a template, mark the holes. Drill a 2" deep hole in the floor with a 5/16" bit. (See fig.5-B.2)
- 3.7 Mark wall bracket mounting holes using the brackets as a template. Center and level the brackets before marking (See fig.3.1). For end-panels and alcove-panels use the outer edge.
- 3.8 Drill 5/16" holes for wall brackets.
- 3.9 Insert plastic anchors (FA-400) into holes.
- 3.10 Secure wall and pilaster brackets with 2" stainless steel screws (FA-808). (See fig.3.2)

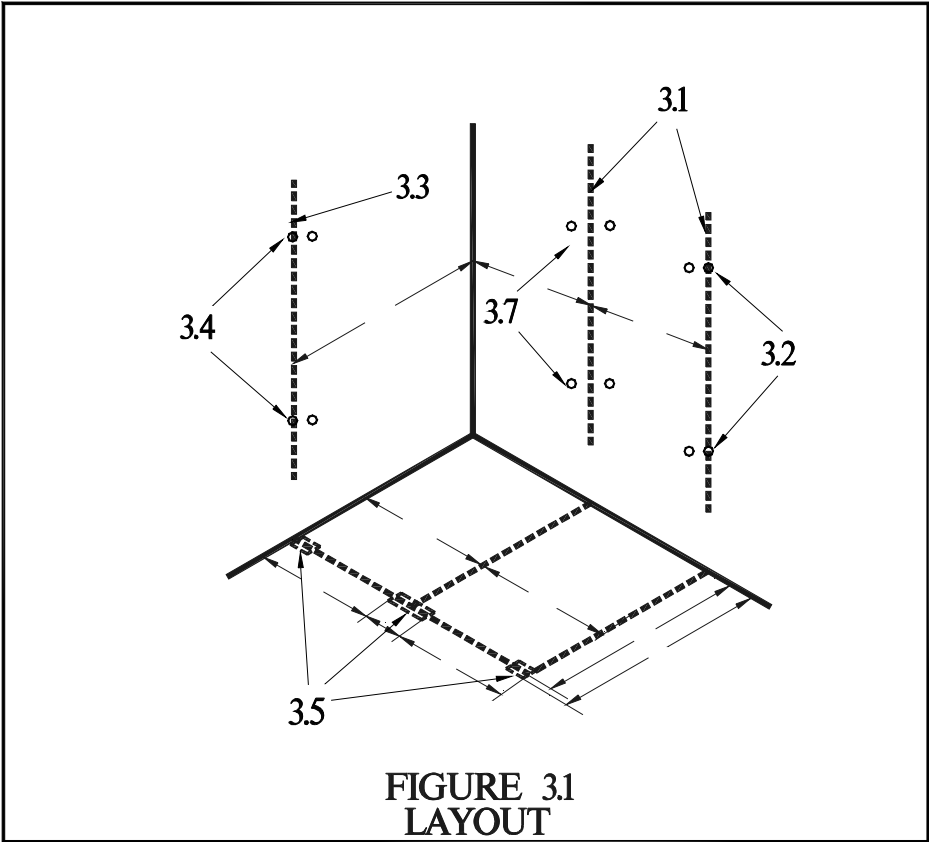

**FIGURE 3.1
LAYOUT**

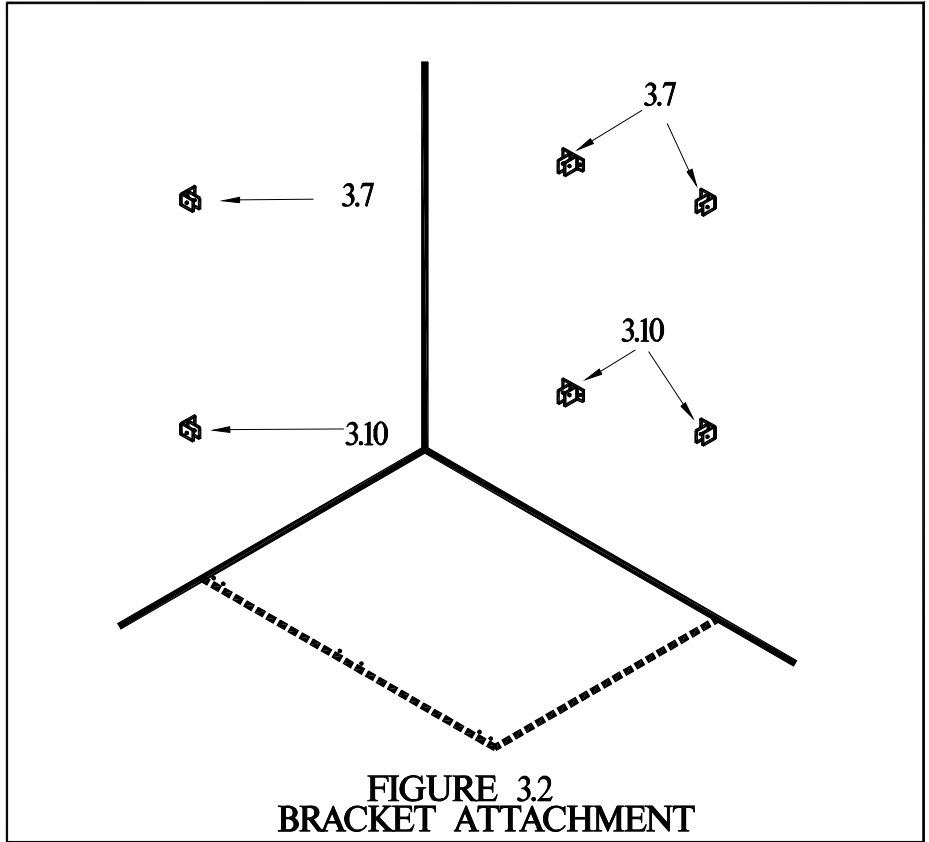

**FIGURE 3.2
BRACKET ATTACHMENT**

4 INSTALL THE PANELS

- 4.1 Place a 12" high support in position to hold up the panels.
(see fig. 4.1)
- 4.2 Set the panel on the support and slide the panel into the wall brackets until the bottom is ½" from the wall.
- 4.3 Drill the bottom bracket hole through the panel with a ¼" drill bit and secure with a ½" bolt (FA-900) and a ½" barrel (FA-950).
- 4.4 Level the top of panel.
- 4.5 Drill the top bracket hole with a ¼" drill bit and secure with a ½" bolt (FA-900) and a ½" barrel (FA-950).
- 4.6 Repeat steps 4.1 through 4.5 for each panel.

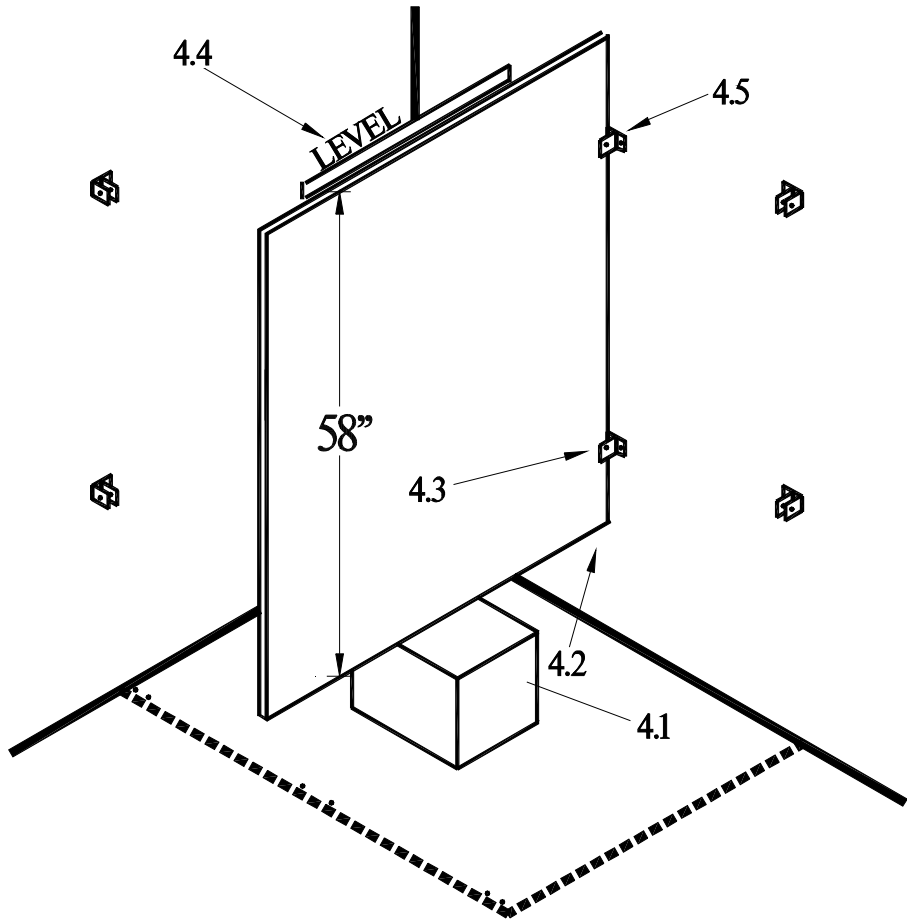
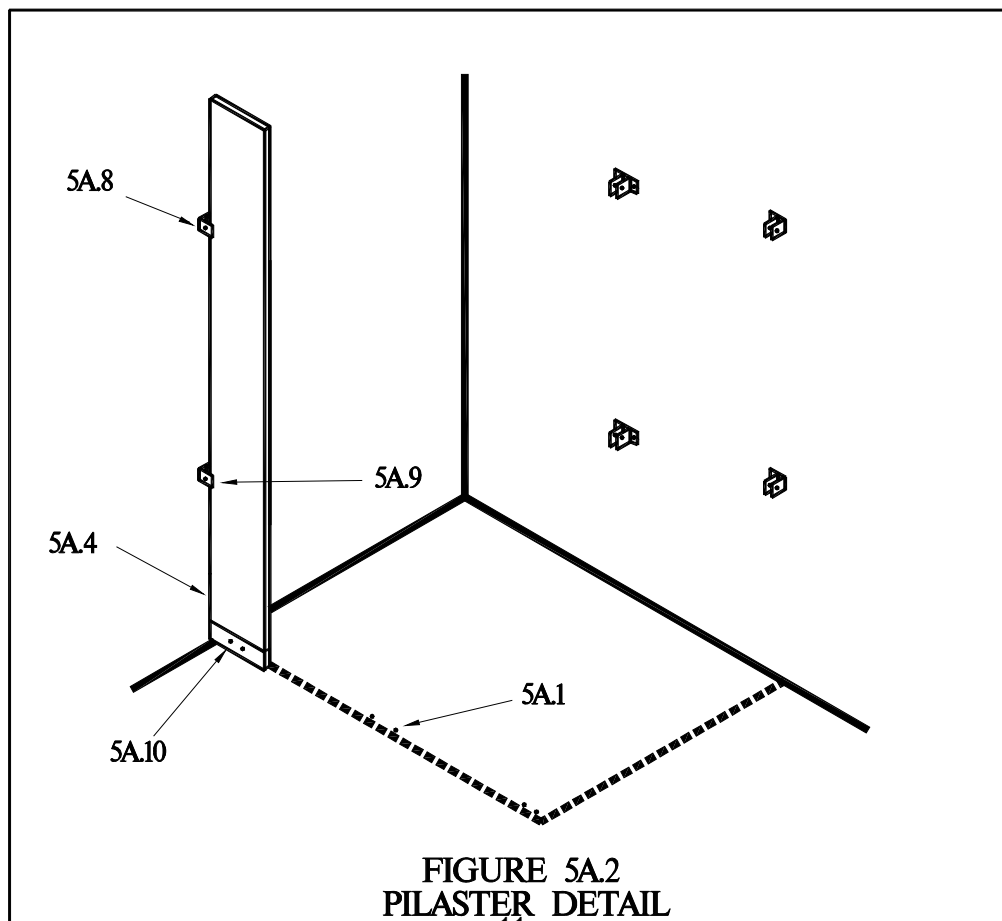
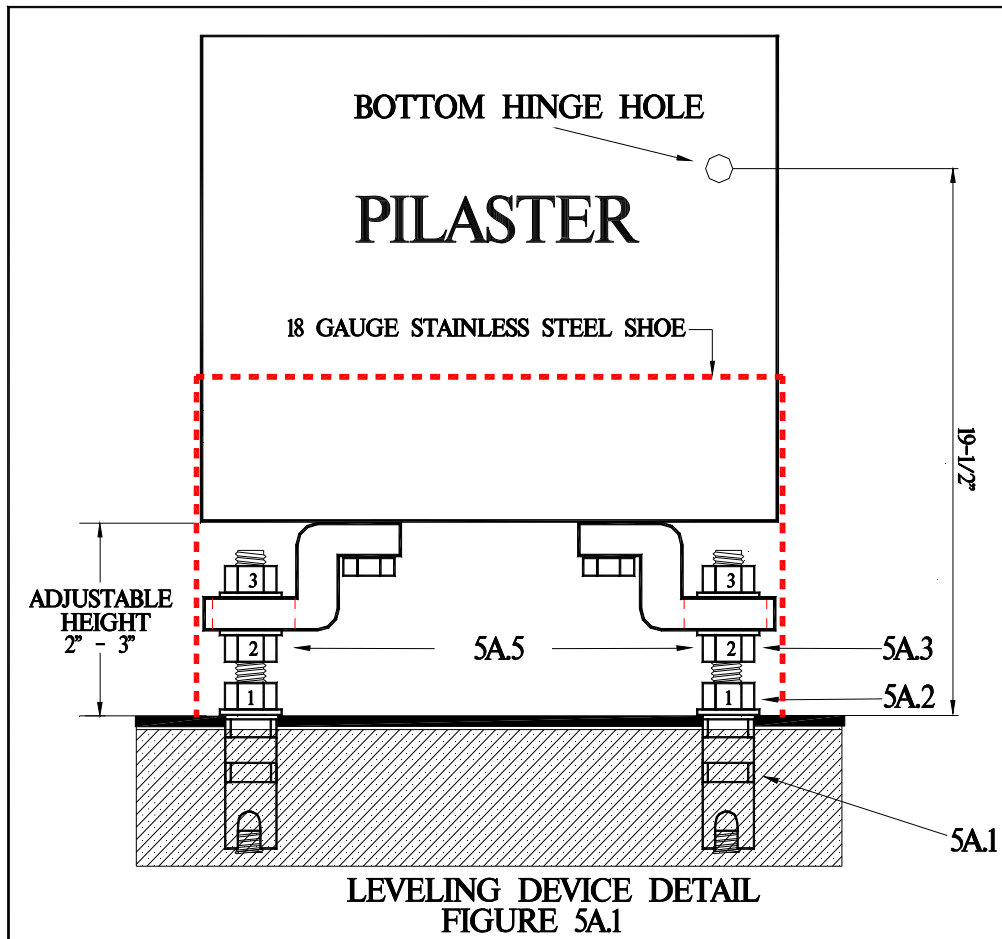

FIGURE 4.1
PANEL INSTALLATION

5 INSTALL THE WALL PILASTER

5A USING 'Z' BAR ANCHORING SYSTEM

- 5A.1 Place a lead anchor into the floor holes from step 3.6.
- 5A.2 Screw a 3/8" x 3 1/2" threaded rod into the lead anchor. Place a 3/8" flat washer and 3/8" nut onto the rod and tighten with a 9/16" wrench to secure the lead anchor.
- 5A.3 Place a second 3/8" nut and 3/8" flat washer onto the threaded rod. Move the nut half way down the rod. (See figure 5A.1)
- 5A.4 Place the wall-pilaster onto the threaded rod and slide it into the wall mounted pilaster-brackets.
- 5A.5 Adjust the 3/8" nut to raise (lower) the pilaster until the bottom hinge hole is 19 1/2" off the finished floor. (See figure 5A.1)
- 5A.6 Place the pilaster shoe onto the pilaster and place the pilaster onto the threaded rod. Place a third washer and nut onto the threaded rod.
- 5A.7 Set the bottom gap between the wall and the pilaster according to the shop drawings. Tighten the top nut to secure the pilaster.
- 5A.8 Level the pilaster. Drill the top pilaster bracket hole with a 1/4" drill bit. Secure with a 1/2" bolt (FA-900) and a 5/8" barrel (FA-951).
- 5A.9 Drill the bottom bracket hole. Secure with bolt and barrel.
- 5A.10 Drill through the shoe and pilaster. Secure with a 1/2" bolt (FA-900) and a 5/8" barrel (FA-951).



5 INSTALL THE WALL PILASTER

5B USING STANDARD LEVELING DEVICE

- 5B.1 Mount the shoe/heel to the floor with 2" stainless steel screws (FA-808).
- 5B.2 Place the pilaster into the shoe/heel and slide the wall-pilaster into the wall brackets.
- 5B.3 Using the Leveling Bolt in the bottom of the pilaster raise (lower) the pilaster to where the bottom hinge hole is 19½" off the finished floor. (See figure 5B.2)
- 5B.4 Place the pilaster into the shoe/heel. Slide the pilaster into the wall brackets. (See figure 5B.1)
- 5B.5 Set the bottom gap between the wall and the pilaster according to shop drawings.
- 5B.6 Drill the bottom bracket hole through the pilaster with a ¼" drill bit. Secure with a ½" bolt (FA-900) and a 5/8" barrel. (FA-951)
- 5B.7 Check level and drill the top hole through the pilaster with a ¼" drill bit. Secure with a ½" bolt (FA-900) and a 5/8" barrel. (FA-951)
- 5B.8 Drill ¼" hole(s) through the shoe, heel and pilaster. Secure the shoe with ½" bolts (FA-900) and 5/8" barrels. (FA-951)

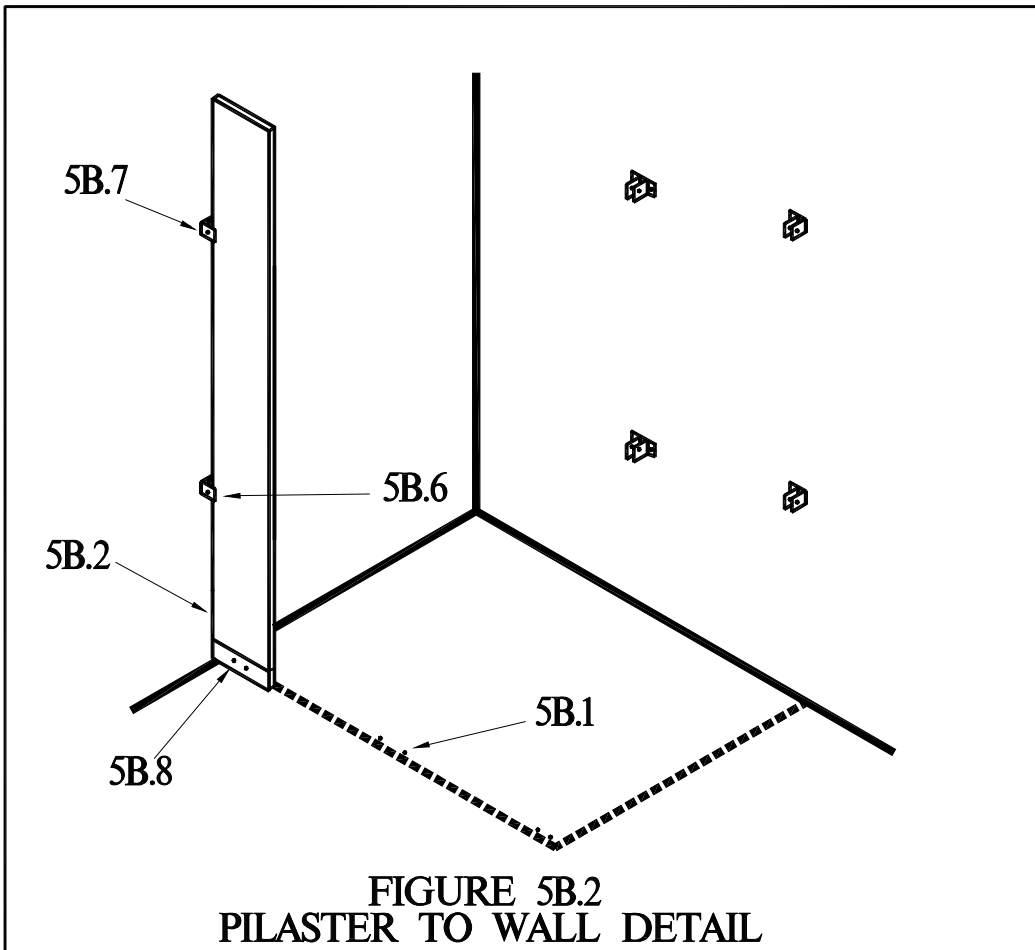
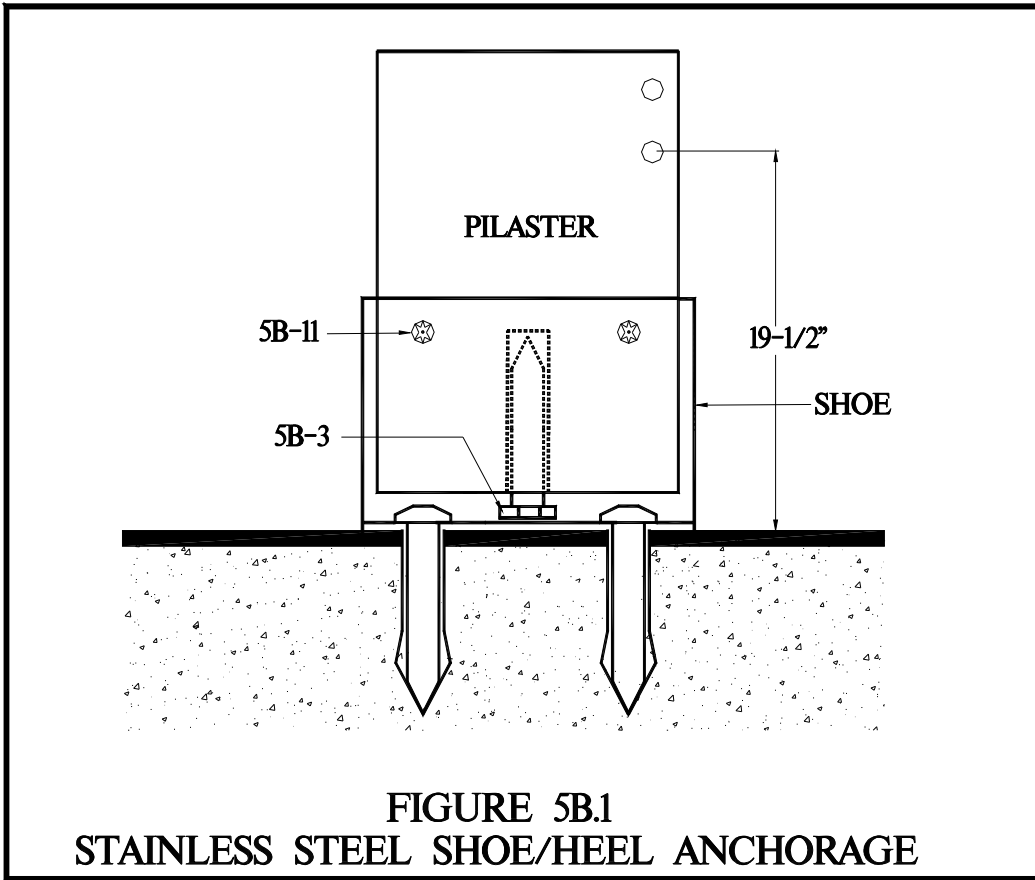

6 INSTALL THE PILASTERS

- 6.1 Prepare the pilaster floor fasteners. For leveling device follow steps 5A.1 through 5A.3. For shoe & heel follow step 5B.1.
- 6.2 Place the pilaster onto the leveling device (or heel) and level the top of the pilaster with the pilaster at the wall.
- 6.3 On the back of the pilaster mark the center of the panel according to shop drawings. (See fig 6.2)
- 6.4 Mark the pilaster where the brackets will be located at 18" and 64" off the floor for shoe/heel, 17" and 63" for leveling device.
- 6.5 Place the pilaster-to-panel brackets onto the pilaster where the marks are made. Mark the mounting holes. (see fig 6.2)
- 6.6 Drill ¼" holes through the pilaster and secure the pilaster-to-panel brackets with ½" bolts (FA-900) and 5/8" barrels (FA-951).
- 6.7 Place the shoe onto the pilaster and place the pilaster onto the leveling device (or shoe/heel). Slide the panel into the bracket.
- 6.8 Secure the pilaster.
 - 6.8.1 For 'Z" bar anchoring system, place a 3/8" washer and nut onto the threaded rods and tighten to secure the pilaster.
 - 6.8.2 For standard leveling device drill level top of pilaster with pilaster at wall, drill a ¼" hole through the shoe and the pilaster. Secure with ½" bolts (FA-900) and 5/8" barrels (FA-951).
- 6.9 Level the pilaster front and drill through the top panel bracket hole. Secure the panel with a ½" bolt (FA-900) and ½" barrel. (FA-950). Drill and secure the remaining panel bracket hole(s).
- 6.10 Repeat steps 6.2 through 6.9 for each pilaster.
- 6.11 For leveling devices secure the shoes. Drill a ¼" hole through the pilaster. Secure the shoes with ½" bolts (FA-900) and 5/8" barrels. (FA-951)

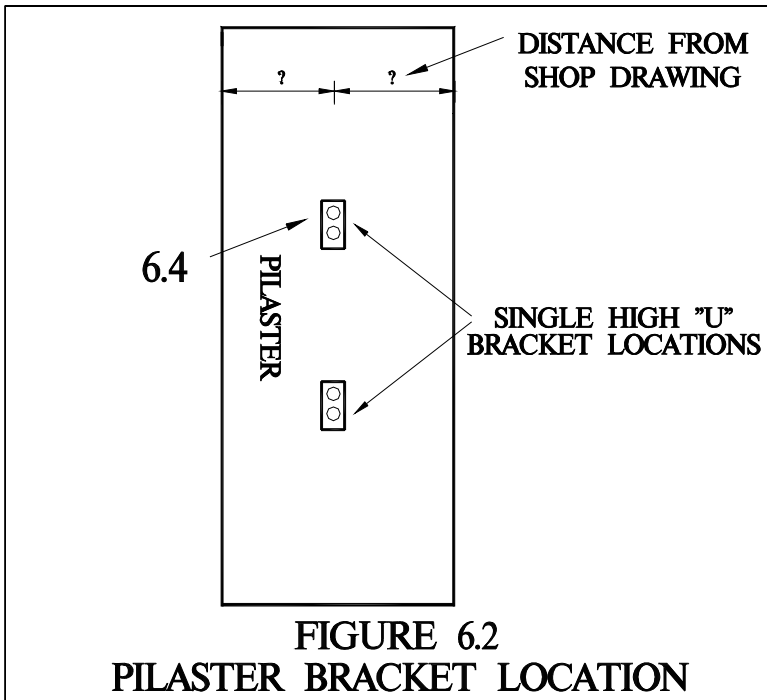
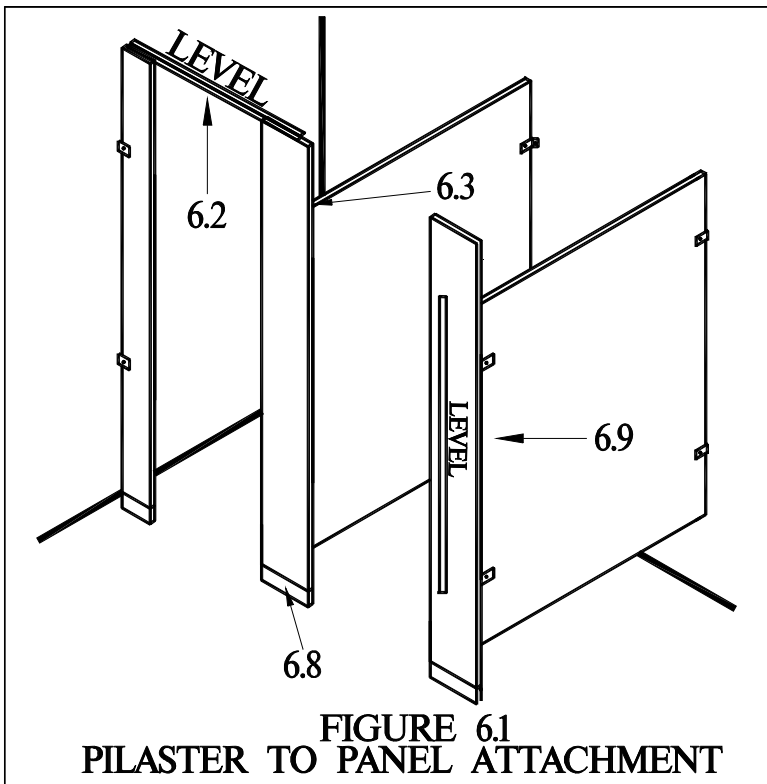

SEE SHOP DRAWINGS FOR DISTANCE BETWEEN
PILASTERS BEFORE FASTENING PILASTERS TO FLOOR.

7 INSTALL THE HEADRAIL

- 7.1 Measure and cut the front headrail to the appropriate length. For large openings, cut the headrail as long as possible with the cut in the center of a pilaster.
- 7.2 Lay the headrail on top of the pilasters and using the headrail bracket as a template attach to wall using the supplied fasteners.
- 7.3 Drill a 1/4" hole through the headrail bracket, headrail and the wall-pilaster. Secure with a 15/16" bolt (FA-902) and 5/8" barrel (FA-951).
- 7.4 For each pilaster, measure and mark the door opening width according to shop drawings. Drill a 1/4" hole through the headrail and the pilaster. Secure with a 3/4" bolt (FA-901) and a 5/8" barrel (FA-951). See the notes to determine how many holes to drill.
- 7.5 For in-corner and free-standing configurations place an end-cap and a corner headrail bracket onto the end of the headrail. Drill a 1/4" hole through the headrail bracket, headrail and pilaster. Secure with a 15/16" bolt (FA-902) and 5/8" barrel (FA-951).
- 7.6 Measure from the top of the panel to the bottom of the corner headrail bracket.
- 7.7 Measure, mark and secure a headrail bracket on the wall at the height measured in step 7.6.
- 7.8 Measure from the back wall to the corner headrail bracket. Cut a piece of headrail to fit between the two brackets. Drill a 1/4" hole through the headrail and bracket and secure with 15/16" bolts (FA-902) and 5/8" barrels (FA-951).

Pilaster Size	# Bolts	Location
< 7"	1	Centered
8" – 13"	2	2" from each end
> 14"	3	2" from each end and one centered

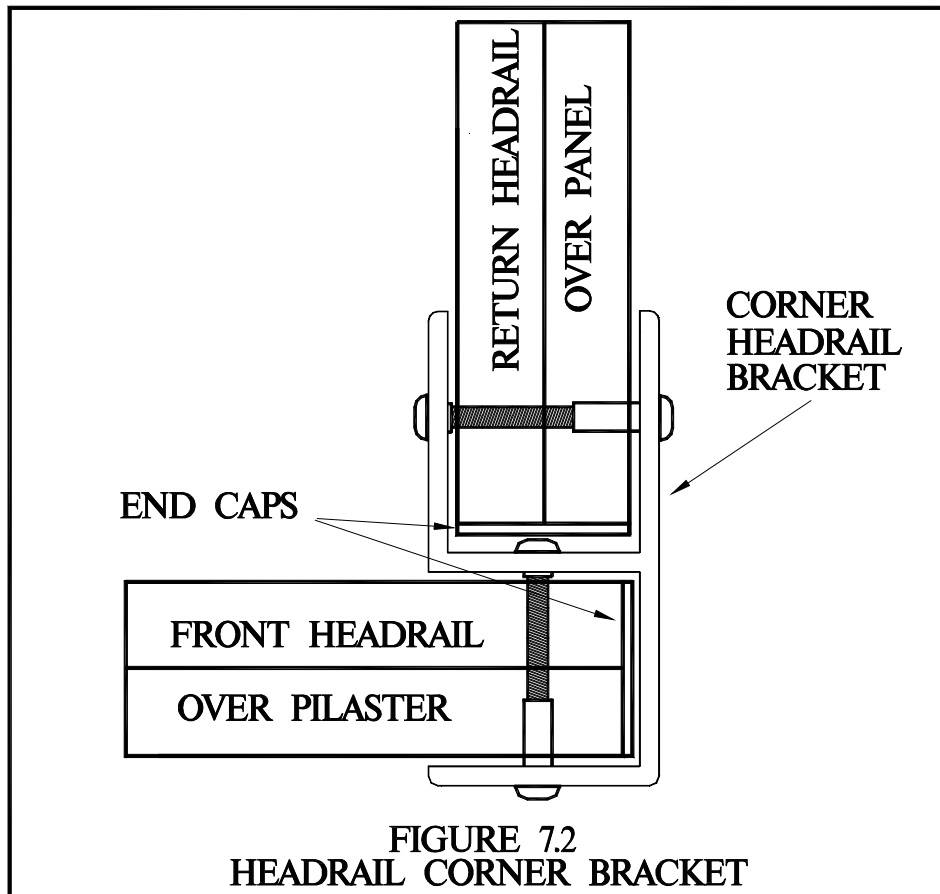
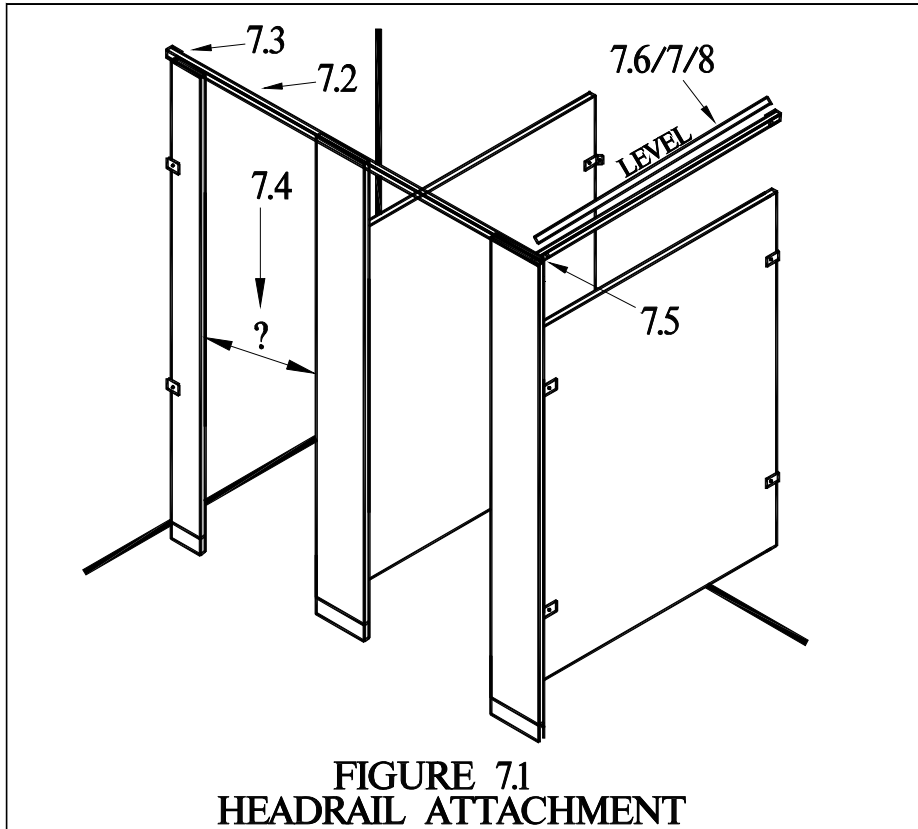

8 ATTACH THE DOORS

- 8.1 Secure part 1 of the top hinge onto the top of the pilaster with 1/2" bolts (FA-900) and 5/8" barrels (FA-951). Keep the adjustable pin in hinge part 1. (See fig. 1)
- 8.2 Secure part 2 of the top hinge onto the top of the door with 1/2" bolts (FA-900) and 5/8" barrels (FA-951). (See fig. 1)
- 8.3 Secure part 3 of the bottom hinge onto the bottom of the pilaster with 1/2" bolts (FA-900) and 5/8" barrels (FA-951). (See fig. 2)
- 8.4 Hang the door onto the pilaster.
- 8.5 Secure part 4 of the bottom hinge to the bottom of the door using 1/2" bolts (FA-900) and 5/8" barrels.

**FIGURE 1
TOP HINGE DETAIL**

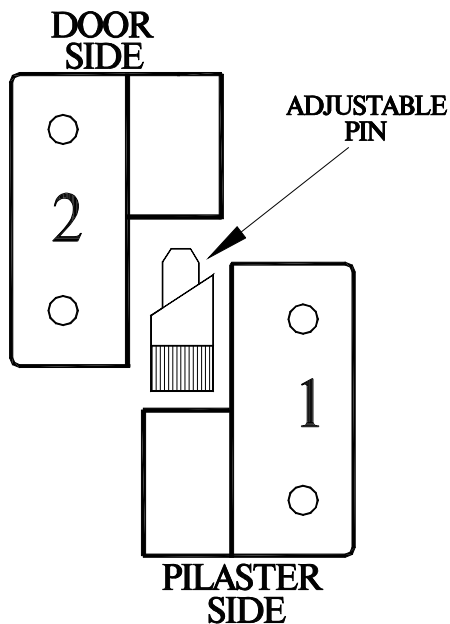

**FIGURE 2
HINGE DETAIL**

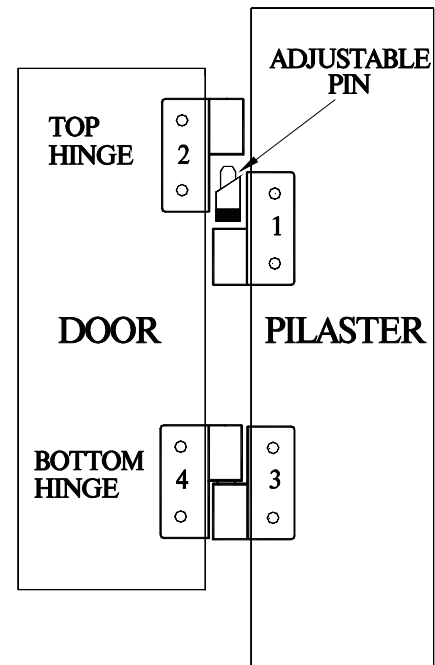

Notes:

- To increase or decrease the default door opening reposition the adjustable pin in the top hinge. The default position is 15° open.
- For the best installation place the barrel through the hinge.
- On inswing doors the hinge is located on the inside of the stall. On outswing doors the hinge is located on the outside of the stall.
- A right hand inswing hinge (SS-151) is also a left hand outswing hinge. A left hand inswing hinge (SS-150) is also a right outswing hinge.

9 ATTACH THE DOOR HARDWARE

9.1 Mark the keeper position on the Pilasters.

9.1.1 For surface mounted latches, measure and mark the center of the keeper 41" above the finished floor.

9.2 Using the keeper as a template, mark and drill ¼" holes through the pilaster. Secure the keepers using ¾" bolts (FA-901) and 5/8" barrels (FA-951).

9.3 Mount the door latch. Position the surface mounted latches on the inside of the door so the latch clears the keeper when the door opens. Using the latch as a template, mark and drill ¼" holes through the door.

9.3.1 For inswing doors, secure the latch with ½" bolts (FA-900) and 5/8" barrels (FA-951).

9.3.2 For outswing doors secure the latch to the door pull with 1-3/16" bolts (FA-904).

9.4 Mount the coat hook / bumper

9.4.1 For inswing doors place the coat hook / bumper 4" from the top and outer edge. Mark and drill ¼" holes in the door. Secure the coat hook / bumper to the inside of the door with 5/8" bolts (FA-609) and ½" barrels (FA-652).

9.4.2 For outswing doors center the coat hook 4" from the top. Mark and drill ¼" holes in the door. Secure the coat hook with 5/8" bolts (FA-609) and ½" barrels (FA-652).

9.4.3 For ADA doors see local specifications for coat hook placement. (usually 48" from the finished floor)

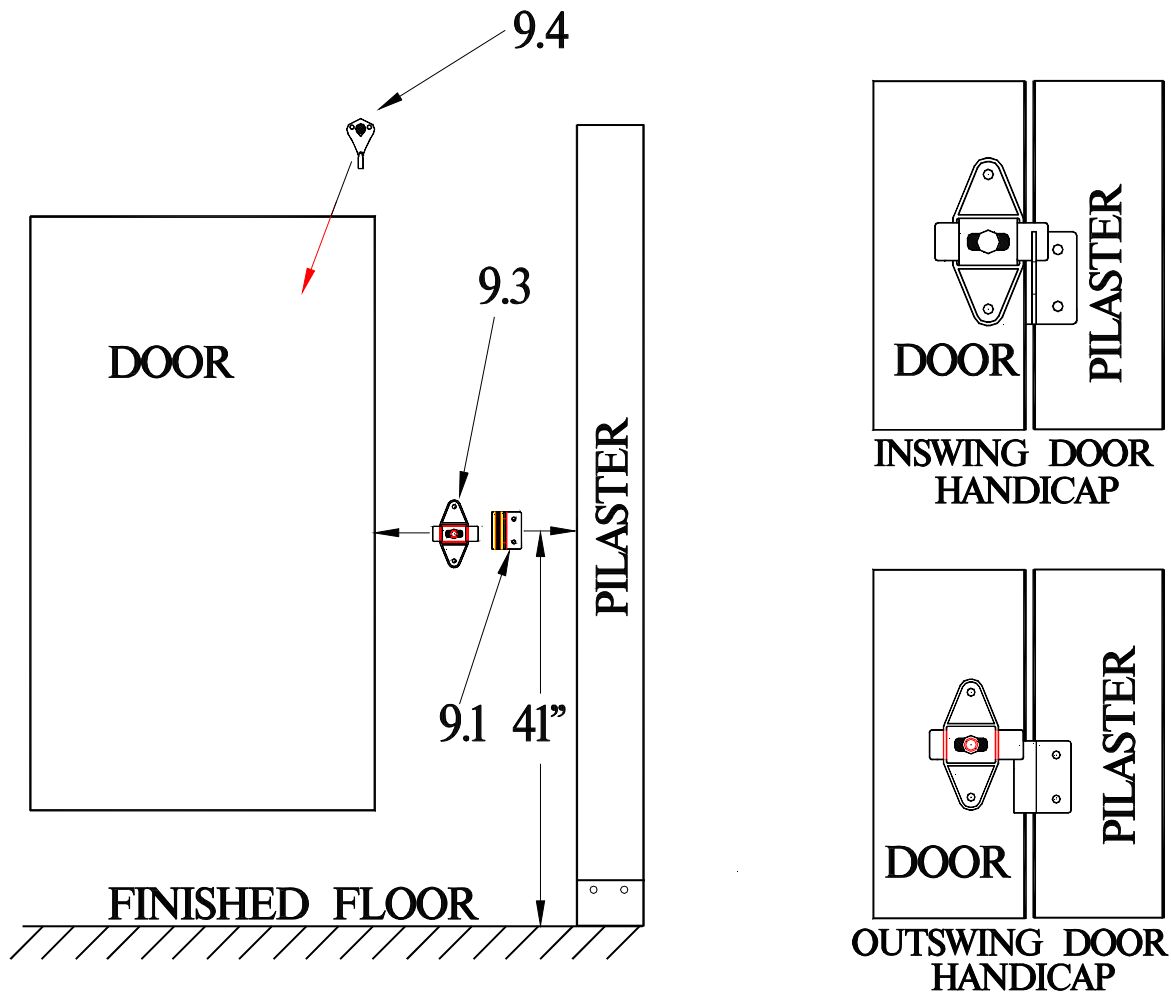

**FIGURE 9.1
DOOR HARDWARE ATTACHMENT**

Notes

- For ADA and emergency access doors mount the latch near the top of the keeper so that when in the latched position the door can be lifted and opened.
- Use the bent end of the latch for the inswing doors and the straight end for the outswing doors.

10 ADJUSTABLE ALUMINUM PILASTERS

INSTALLATION INSTRUCTIONS:

- MOUNT PIECE 'B' TO WALL
12" ABOVE FINISHED FLOOR.
- PLACE PIECE 'A' OVER PIECE 'B'
AND ADJUST TO PROPER WIDTH.
- DRILL FOR AND INSTALL THROUGH-BOLTS.

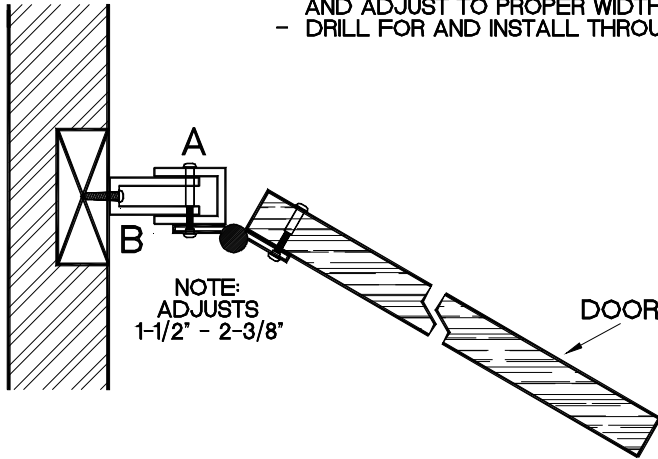







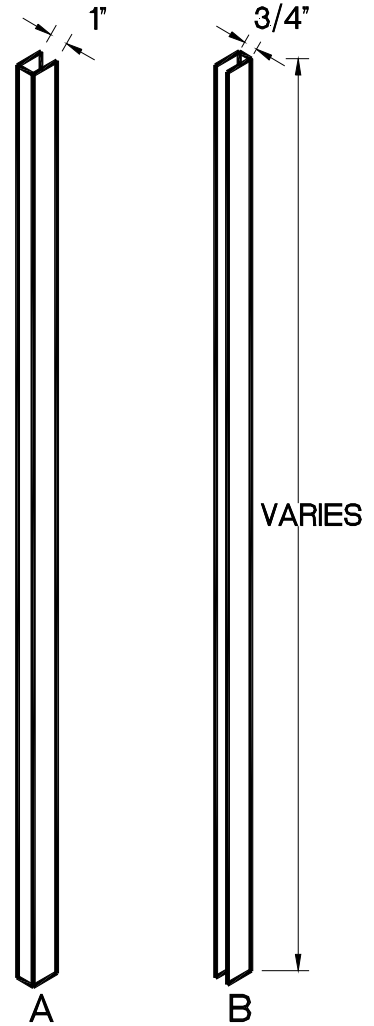

3/4" - 1" ADJUSTABLE	
(5) 1-1/2" ANCHORS	FA-400
(5) 1-1/2" SCREWS	FA-801
(5) 3/4" BOLTS	FA-901
(5) 5/8" BARRELS	FA-951

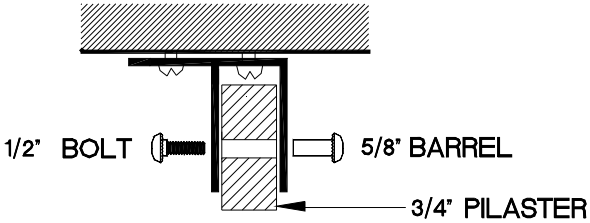
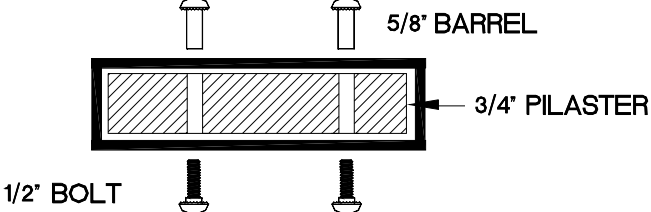
NOTE: EA 1" ADJUSTABLE PILASTER
RECEIVES THE ABOVE HDWE.

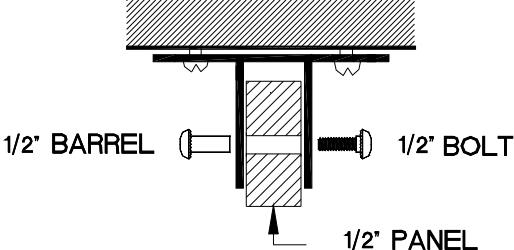
ADJUSTABLE ALUMINUM PILASTER
FIGURE 10.1

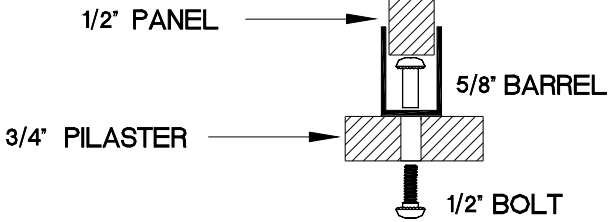

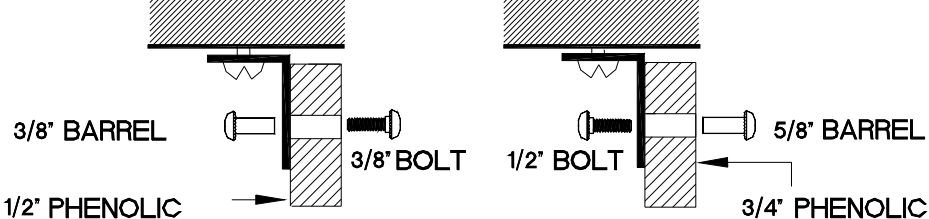
11 BOLT AND BARREL SIZES

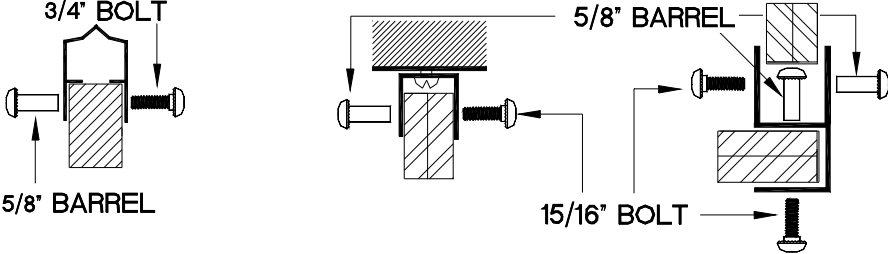
<p>PILASTER BRACKETS</p> 	 <p>1/2" BOLT</p> <p>5/8" BARREL</p> <p>3/4" PILASTER</p>
<p>SHOES</p>	 <p>5/8" BARREL</p> <p>3/4" PILASTER</p> <p>1/2" BOLT</p>
<p>PANEL BRACKETS</p> 	 <p>1/2" BARREL</p> <p>1/2" BOLT</p> <p>1/2" PANEL</p>
<p>PANEL TO PILASTER BRACKETS</p> 	 <p>1/2" PANEL</p> <p>3/4" PILASTER</p> <p>5/8" BARREL</p> <p>1/2" BOLT</p>
<p>ANGLE BRACKETS</p> 	 <p>3/8" BARREL</p> <p>1/2" PHENOLIC</p> <p>3/8" BOLT</p> <p>1/2" BOLT</p> <p>5/8" BARREL</p> <p>3/4" PHENOLIC</p>
<p>HEADRAIL BRACKETS</p> 	 <p>3/4" BOLT</p> <p>5/8" BARREL</p> <p>5/8" BARREL</p> <p>15/16" BOLT</p> <p>HR TO WALL BRACKET</p> <p>CORNER HR BRACKET</p>



**PARTITION SYSTEMS INTERNATIONAL
OF SOUTH CAROLINA**

"Promoting a Greener Environment"

A DIVISION OF CSISC®

803-252-3020

www.psisc.com

Copyright 2020

© 2020 by Partition Systems International of South Carolina (PSISC ®)